



Features:

1. Comply with ANSI/EIA; RS-310-D; DIN41491; IEC297-2; DIN41494; PART7 GB/T3047.2-92 standard; compatible with 19" international standard, metric system and ETSI standard.
2. SPCC cold roll steel frame, Maximum static loading: 500KG.
3. 2.0mm thick Mounting Rails and 1.2mm thick Mounting Angle enables sturdy mount.
4. Tempered glass front door, Steel back for mechanical protections.
5. Cable Entry on top cover and bottom panel enables hassle-free cable patching.
6. Removable front & rear door and side panel for accessing facilities and ventilation.
7. Vent holes on the top and bottom provide good ventilation throughout the rack.

Accessories:

Fixed Shelf
FS45B / 6UB

AC Fan
ACF2B

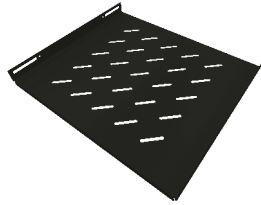

Models and Dimensions:

Model	U	H	W	D	Fixed Shelf	AC Fan	M6 Screw	Weight (KG)
450D Model								
RW6404B	4	278	600	450			10	17
RW6406B	6	367	600	450			10	20
RW6409B	9	500	600	450			10	22
RW6412B	12	650	600	450			20	25
RW6415B	15	775	600	450			20	29
RW6418B	18	908	600	450			20	35
600D Model								
RW6606B	6	367	600	600			20	22
RW6609B	9	500	600	600			20	27
RW6612B	12	650	600	600			20	30
RW6615B	15	775	600	600			20	35
RW6618B	18	908	600	600			20	38

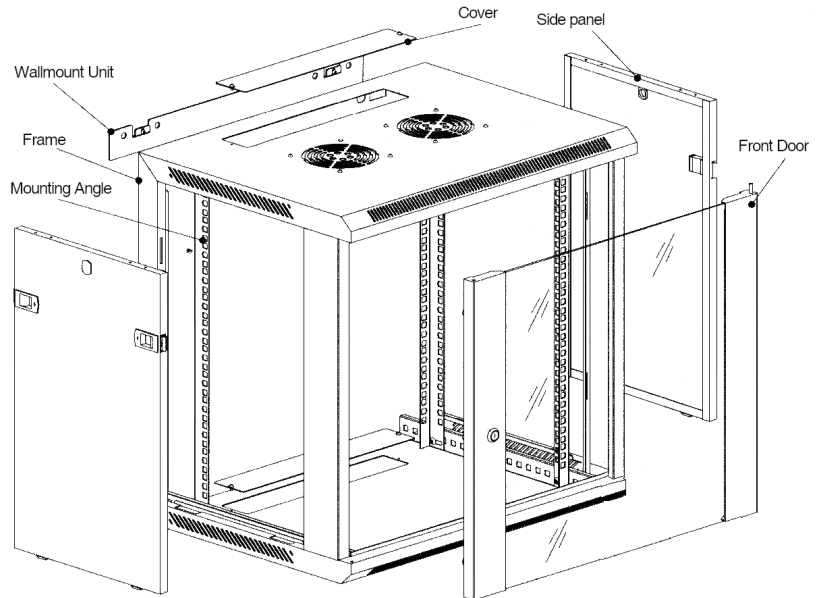

Structural Diagram